

Durasweeper ST-200 Commercial Vehicle Rooftop Specification



Merxway ApS, Org No 37951579, Copenhagen, Denmark
Tel: 0045 22711126, 00370 648 56000
E-mail: europe@durasweeper.eu
Website: www.durasweeper.eu

GENERAL SPECIFICATIONS



DURASWEEPER
REMOVE SNOW SAFELY

FEATURE	DURASWEEPER	UNITS
Unit height	6293	mm
Unit width	9508	mm
Unit length	3988	mm
Frame weight	1554	Kg
Total weight	2400	Kg
Input power	10 kW (20A) 400V, three-phase, 50 Hz	kW, V Hz
Max. working height	5405	mm
Min. working height	416	mm
Max. truck width	3000	mm
Brush segment diameter	800	mm
Brush material	Polypropylene (blue)	N/A
Brush segment	1200 (x3)	mm
Average snow removal time	0.45 (for 13.6 m truck length)	min
Recommended speed	3	km/h
Unit structure	Stainless Steel (AISI 304)	N/A
Structure finish	Airless spray painting	N/A
Concrete pad	See provided foundation plan	N/A
Levering dispersion sound Pressure scale in working place	71.5	dBA

FEAUTURE	ELECTRIC DURASWEEPER	UNITS
Lenze - brush drive mechanism		
Rated power	7,5	kW
Rated frequency	50	Hz
Ratio	8,517	-
Output speed	173,8	r/min
Output torque	392	Nm
Load capacity	1,17	-
Lenze - vertical position mechanism		
Rated power	1.1	kW
Rated frequency	50	Hz
Ratio	164.833	-
Output speed	8.9	r/min
Output torque	1123	Nm
Load capacity	1.34	-

ENGINES SPECIFICATION



DURASWEEPER
REMOVE SNOW SAFELY

**Maximum brush working height (max truck height) – 5405 mm.
Maximum truck width – 3000 mm**

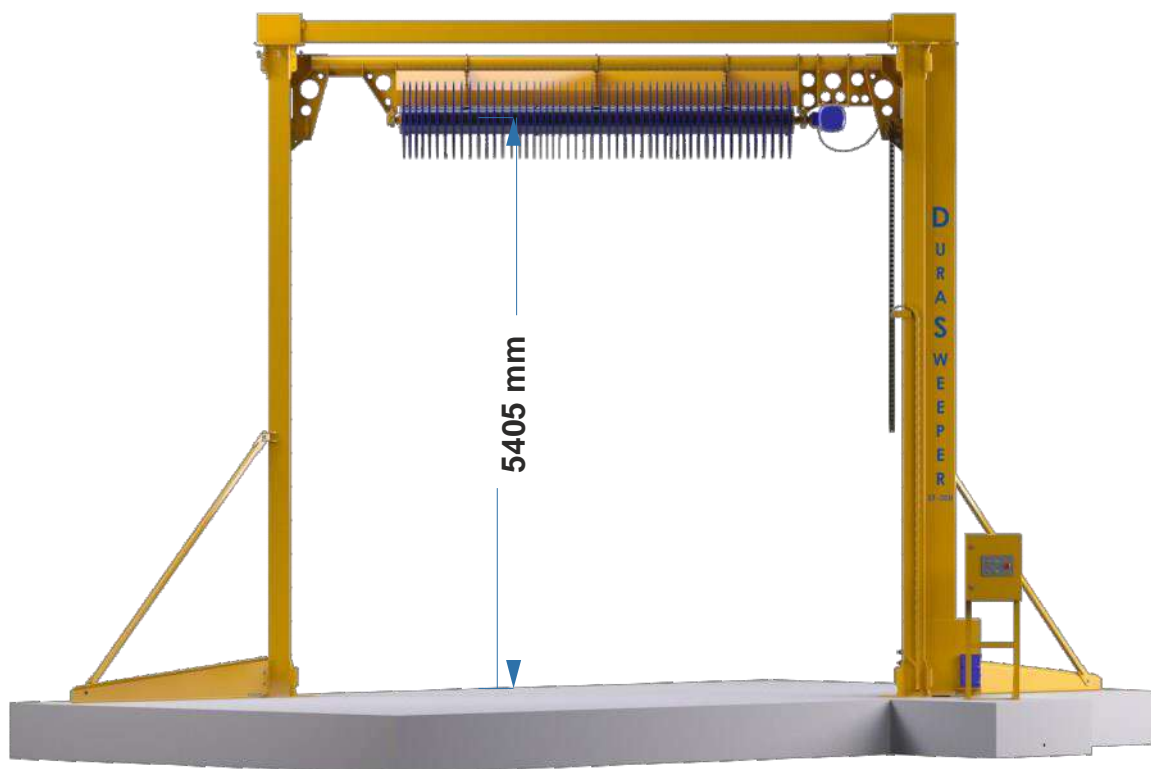

Minimum brush working height – 416 mm

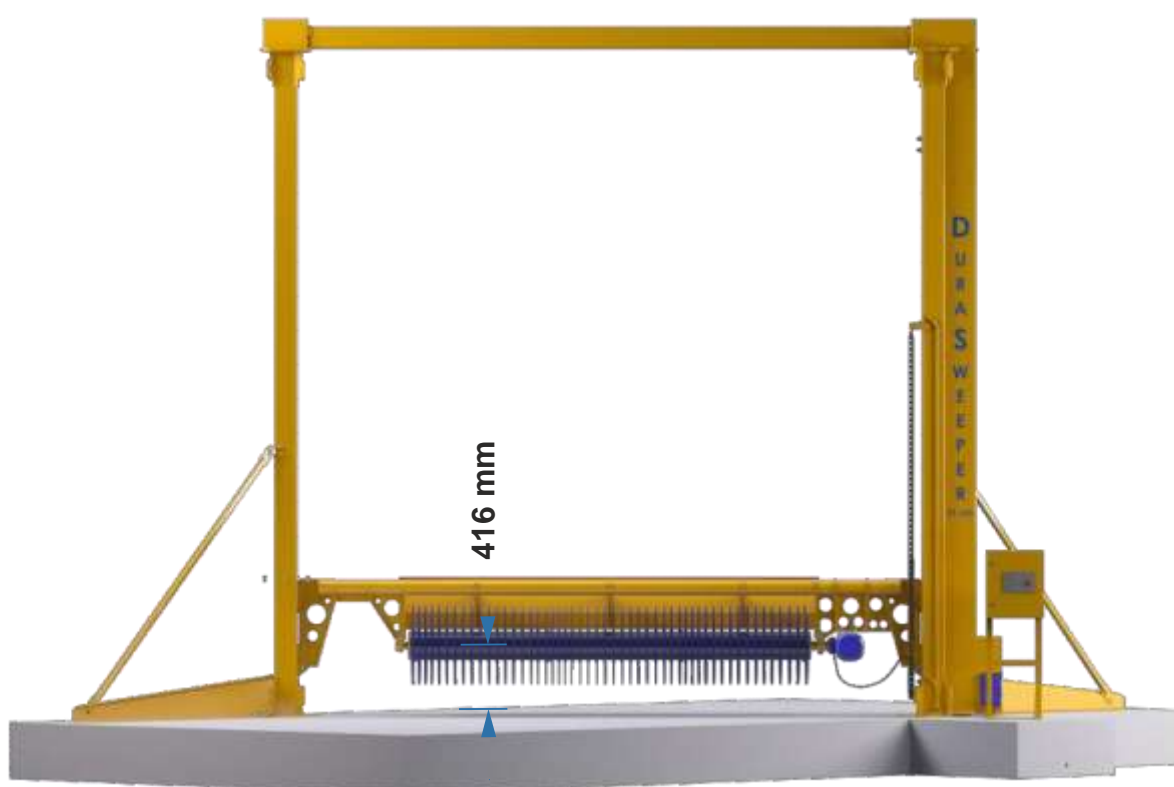

REQUIRED SITE AREA

